

USB Ultra Violet Sensor | SU-420

USB UV sensor can be connected directly to a computer for real-time measurements and data logging, or can act as a stand-alone datalogger when connected to most standard 5 V DC USB power sources.

Wide Range

Sensitive from 250 to 400 nm, spanning the solar UV and range of electric lamps.

Measurement Units

Software give the sensor the option to take measurements in either photon flux density units [$\mu\text{mol m}^{-2} \text{s}^{-1}$] or energy flux density [W m^{-2}].

No Datalogger Required

Sensors can be connected to a desktop, laptop, or tablet computer via a USB 2.0 type A plug, to be used with ApogeeConnect software. The software gives user control of data logging settings, provides a real-time output display and graph of measurements, and allows the data set to be saved as a csv file for further analysis.

Internal Data Storage

Sensor has internal data storage capability with the ability to hold up to 10,000 measurements. This allows the sensor to collect data while connected to most stand-alone 5 V DC USB power sources.

Rugged, Self-cleaning Housing

The patented domed shaped sensor head facilitates runoff of dew and rain, helping to keep the detector clean and minimizing errors caused by dust blocking the radiation path. Sensors are housed in a rugged anodized aluminum body and electronics are fully potted.

Typical Applications

Applications include: UV radiation measurement in outdoor environments (sensor is not recommended for long-term continuous outdoor deployment), laboratory use with artificial light sources (e.g., germicidal lamps), and monitoring the filtering ability and stability of various materials.



Spectral Response

Spectral response estimate of Apogee SU series UV sensors. Spectral response measurements were made at 10 nm increments across a wavelength range of 200 to 450 nm in a monochromator with an attach electric light source. Measured spectral data were normalized at 350 nm.

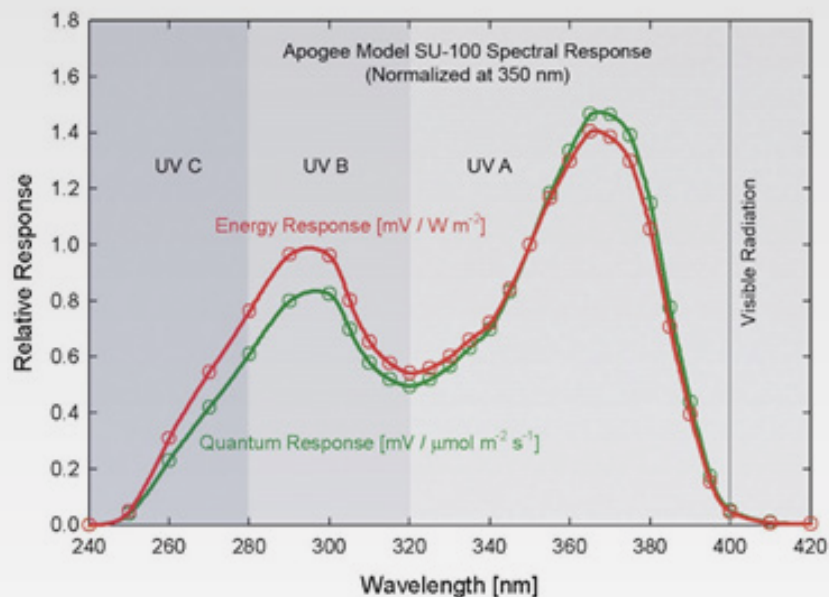

In addition to naturally occurring UV radiation from the sun, there are many electric light sources that emit UV radiation (e.g., cool white fluorescent, metal halide, mercury arc, and germicidal lamps). Although the relative wavelengths of UV radiation differ among sunlight and electric lights, the error estimates shown in the table below indicate that the SU-420 provides reasonable estimates of UV radiation coming from electric lamps (table provides spectral error estimates for UV radiation measurements from radiation sources other than clear sky solar radiation).

Spectral Errors for UV Radiation Measurements with Apogee SU Series UV Sensors

Radiation Source (Error Calculated Relative to Sun, Clear Sky)	Error [%]
Sun (Clear Sky)	0.0
Sun (Cloudy Sky)	< 0.5
Reflected from Grass Canopy	< 0.5
Reflected from Deciduous Canopy	< 0.5
Reflected from Conifer Canopy	< 0.5
Reflected from Agricultural Soil	< 0.5
Reflected from Forest Soil	< 0.5
Reflected from Desert Soil	< 0.5
Reflected from Water	< 0.5
Reflected from Ice	< 0.5
Reflected from Snow	< 0.5
Cool White Fluorescent (T5)	9.0
Metal Halide	2.8
High Pressure Sodium	-1.7
Incandescent	-3.3
Mercury Arc	17.8

Calibration Traceability

Apogee SU-420 UV sensors are calibrated through side-by-side comparison to the mean of four Apogee model SU-100 transfer standard UV sensors under high intensity discharge metal halide lamps. The transfer standard UV sensors are calibrated through side-by-side comparison to an Apogee model PS-200 spectroradiometer under sunlight (clear sky conditions) in Logan, Utah. The PS-200 is calibrated with a LI-COR model 1800-02 Optical Radiation Calibrator using a 200 W quartz halogen lamp. The 1800-02 and quartz halogen lamp are traceable to the National Institute of Standards and Technology (NIST).

Dimensions

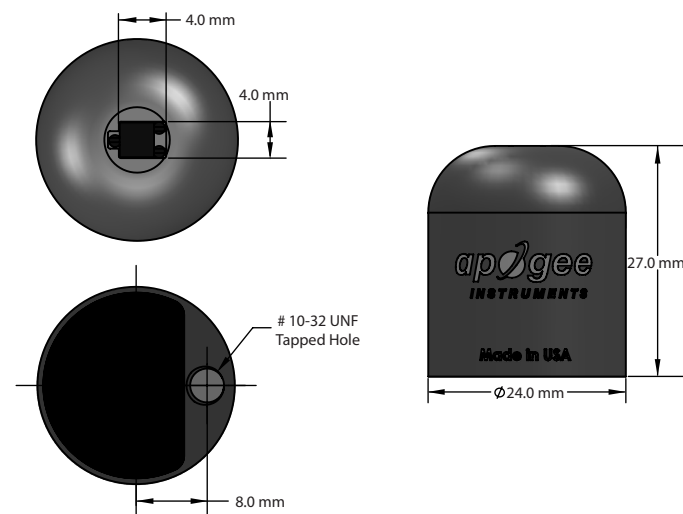

SU-420

Resolution	0.1 W m ⁻²
Calibration Factor	Custom for each sensor and stored in firmware
Calibration Uncertainty	± 10 %
Measurement Repeatability	Less than 1 %
Long-term Drift (Non-stability)	Less than 3 % per year
Non-linearity	Less than 1 % (up to 300 μmol m ⁻² s ⁻¹)
Response Time	Software updates every second
Field of View	180°
Spectral Range	250 nm to 400 nm
Directional (Cosine) Response	± 10 % at 75° zenith angle
Temperature Response	Approximately 0.1 % per C
Operating Environment	-40 to 70 C; 0 to 100 % relative humidity
Dimensions	24 mm diameter, 28 mm height
Mass	Sensor head weighs 90 g
USB Cable	4.6 m (15 ft)
Current Draw (when Logging)	61 mA
Warranty	4 years against defects in materials and workmanship